

# STEALTH 1500B Breakdown

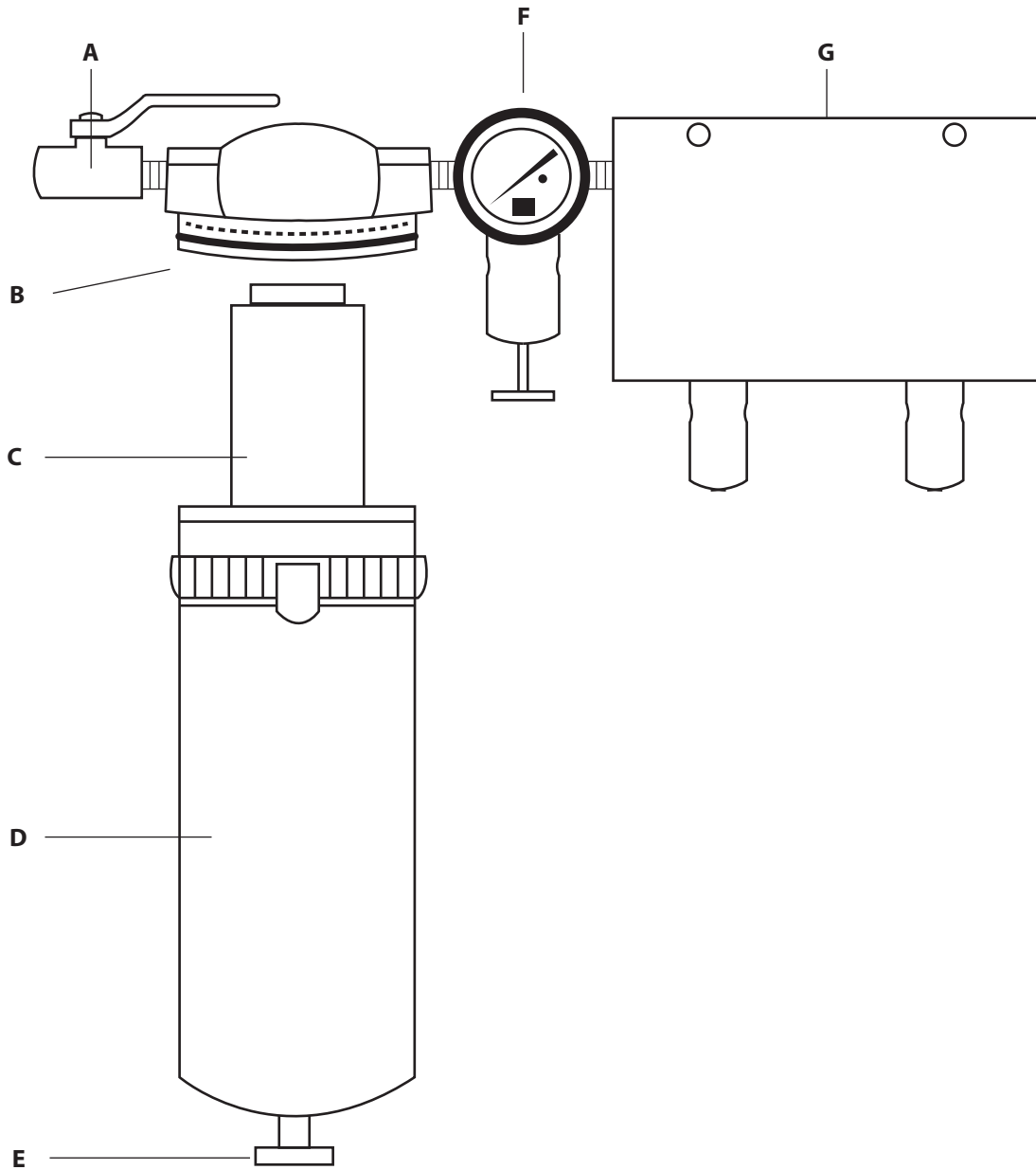

## Description

- A** Ball Valve, 1/2"
- B** Bowl O-ring
- C** Replacement Element
- D** Bowl Assembly

## Part #

- BV-051
- N32-95-257
- 3C-060
- N34-95-205

## Description

- E** Petcock Drain, 1/4"
- F** Regulator/Gauge,
- G** Multiport Manifold w/ Couplers

## Part #

- PC-02
- R500-G
- MA500-4

